

• AC Sweep/Noise analiza

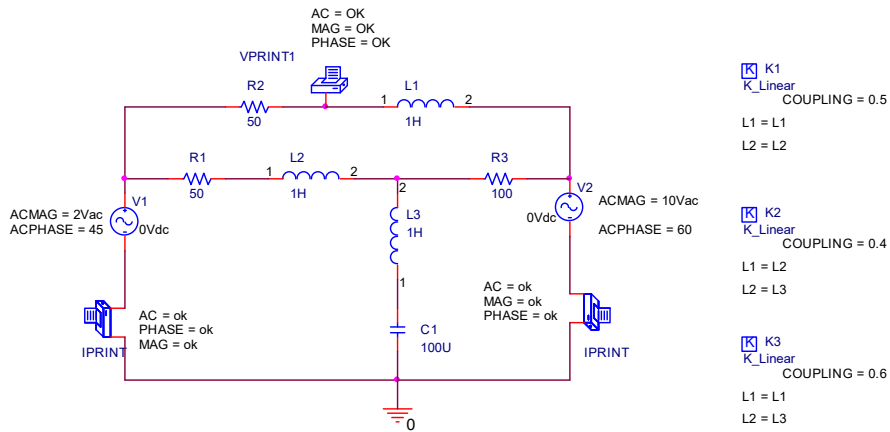

1. AC Sweep/Noise -fazori

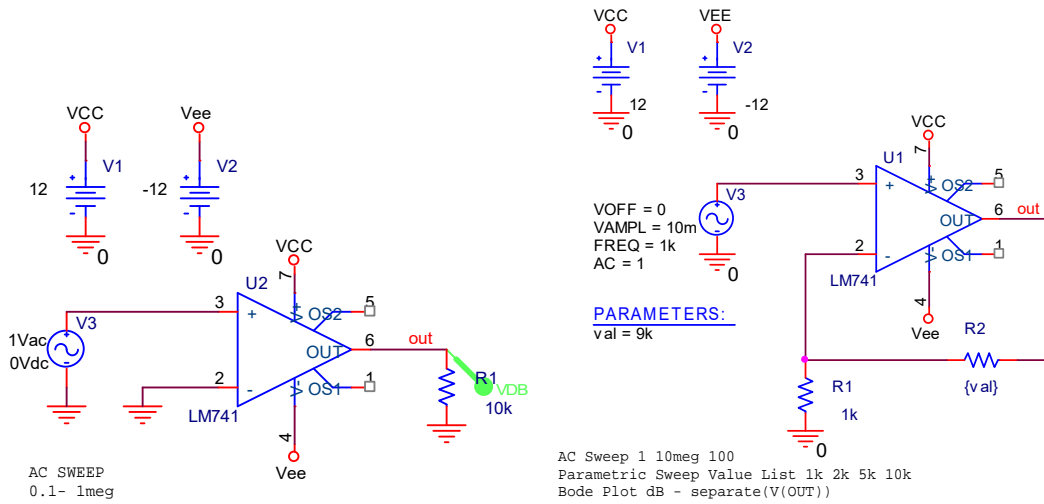

2. AC Sweep/Noise – OPAMP, frekvencijske karakteristike

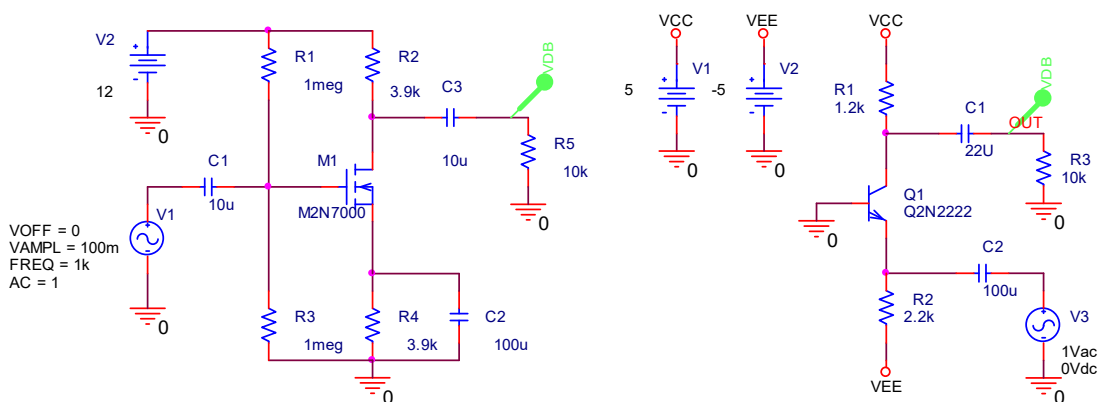

3. AC Sweep/Noise MOS, BJT