

tran: 2m

### 1. Modelovanje analognih kola

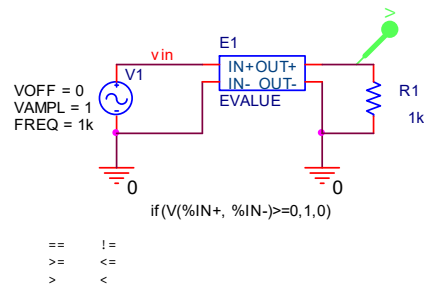

### 2. IF-THEN

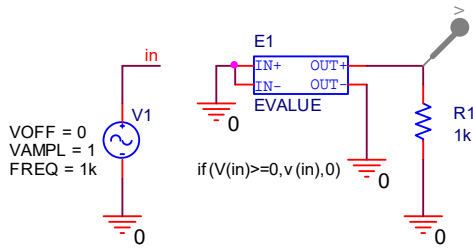
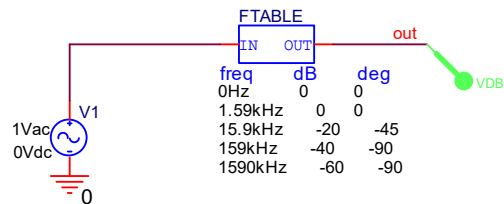
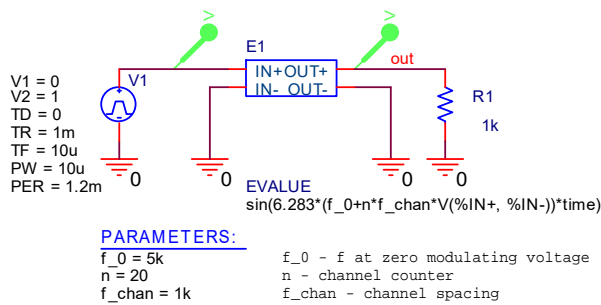

TRAN 2.4m  
MAXIMUM STEP SIZE 20N

### 3.VCO

### 4. Tabela zadavanje funkcije prenosa filtra

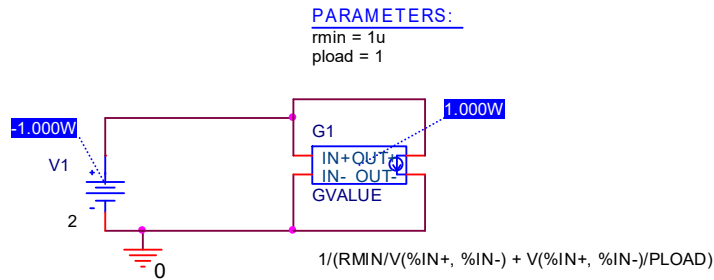

### 5. Modelovanje potrošača sa konstantnom snagom potrošnje.

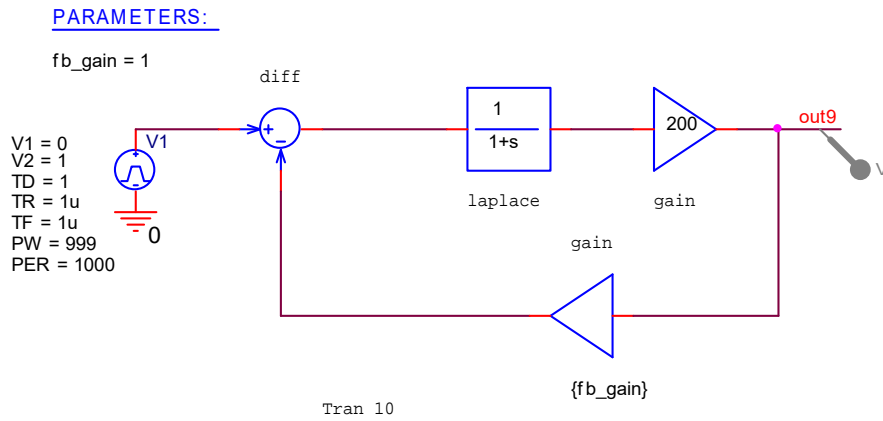

### 6. ABM – Modelovanje kola sa povratnom spregom – Feedback System



### 7. Stimulus Editor

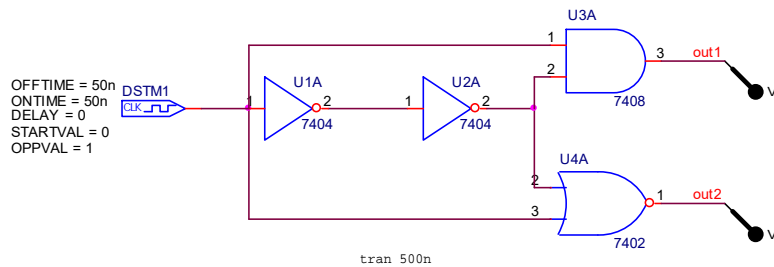

### 8. Simulacija digitalnih kola i uočavanje kašnjenja

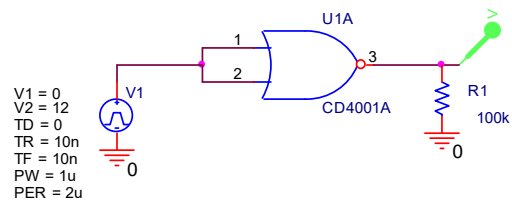

PARAMETERS:  
cd4000\_vdd = 12

## 9. Promena napona napajanja logickih kola